

eZyvalve[®]4

ALL IN ONE VALVE BOX WITH 4 VALVES

INSTALLATION GUIDE

9Vdc



- * 3/4" NPT threads
- * Compact size
- * Water resistant
- * Patented design
- * Lid with o-ring seal
- * UV stable materials
- * Up to 100 psi inlet pressure
- * No internal pipe connections
- * High impact resistant materials
- * Above or below ground installation



eZyvalve®4

eZyvalve®4 Pressure Loss	
Flow Rate (gpm)	Pressure Loss (psi)
3	5
4	9
5	14
6	20
7	27
8	34

Operating Specifications

Flow: 3 gpm to 8 gpm

Pressure: 5 psi to 100 psi

Ambient Temperature: 35°F to 140°F

Electrical: 9Vdc, inrush current 1200 mA

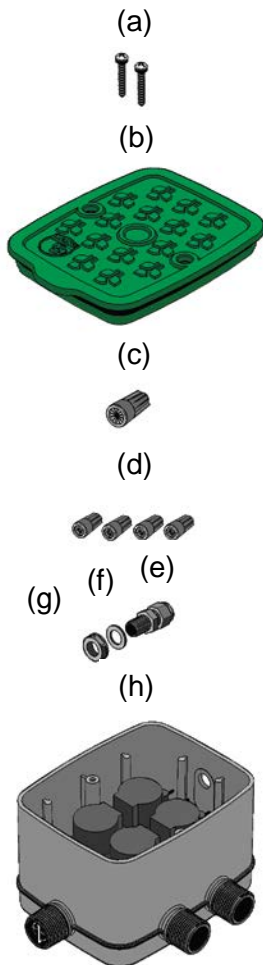

Introduction

The eZyvalve®4 9Vdc must be connected to a battery powered DC irrigation controller. The valve box must be installed in a horizontal position with the lid on top of the product. eZyvalve®4 is suitable for use in damp, wet and rainy conditions but is not designed to be used for continuously submerged applications.

When designing your irrigation system, refer to your local building codes for plumbing and electrical requirements.

If the water supply is non-potable, you may need filtration. Contact your local irrigation contractor / supplier for further advice.

Flushing the mains before connection and the irrigation lines after connection minimises the risk of small particles in the water affecting the performance of the valves and downstream micro irrigation components.

In freezing climates, winterization is needed to remove water from the irrigation system to ensure that freezing and the expansion of water do not damage the components. This may be accomplished by draining the system.

eZyvalve®4 contents:

- (a) 2 stainless steel screws with sealing washers
- (b) 1 lid with "O" ring
- (c) 1 Dryconn® electrical wire connector (large)
- (d) 4 Dryconn® electrical wire connectors (small)
- (e) 1 cable gland suitable for #18 AWG 5-core multi-strand direct burial cable
- (f) 1 washer for cable gland
- (g) 1 hexagonal nut for cable gland
- (h) 1 eZyvalve®4 valve box with 4 inbuilt 24Vac solenoid valves with 7" cables

You will need:

- * 4 station DC battery powered programmable irrigation controller - check compatibility with your supplier
- * A maximum 30 ft length of #18 AWG 5-core multi-strand direct burial controller cable
- * Plumbers thread-seal tape
- * Wire cutters and / or wire strippers
- * Screw driver
- * Appropriate fittings and tube for your irrigation system

eZyvalve[®]4

Installation instructions

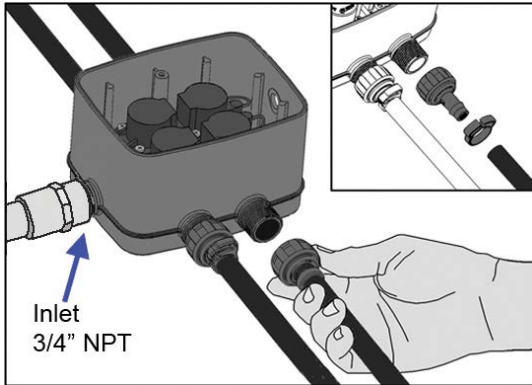

(Fig 1)

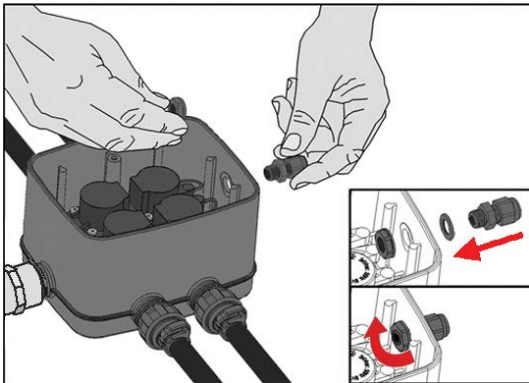

(Fig 2)

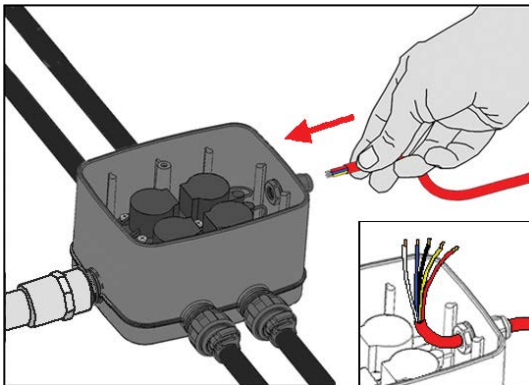

(Fig 3)

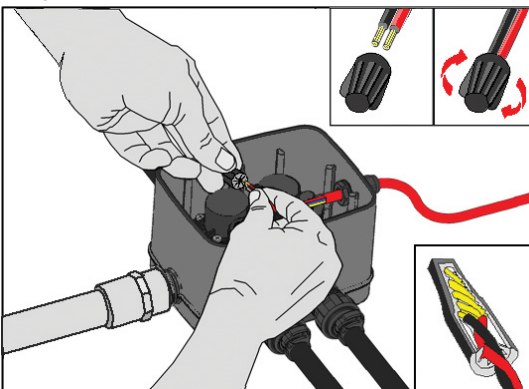

(Fig 4)

1. Connect the water supply to the 3/4" NPT inlet thread of the eZyvalve[®]4 valve box (h). Use only plumber's thread tape to seal threads - do not use pipe sealant paste. Connect your irrigation lines to each of the four 3/4" NPT threaded outlets. Cap unused outlets. (Fig 1)

2. Assemble the cable gland (e) by removing the hexagonal nut (g) and pushing the cable gland (e) through the hole in the end of the eZyvalve[®]4 box (h), with the washer (f) on the outside of the box. Replace the hexagonal nut on the inside of the box and tighten. (Fig 2)

3. Loosen the hexagonal sealing nut on the outside of the cable gland (e) and push the controller cable through the gland, allowing enough cable inside for connection to the solenoid leads. Ensure the outer sheathing of the cable penetrates through the cable gland. Strip 3 inches of outer sheath from the controller cable ensuring you do not damage the inner cores. Next, strip 5/8 inch of insulation from the end of each inner wire and align any frayed strands. (Fig 3)

4. Note: The polarity of the wire connections is critical in a DC solenoid. Refer to your controller instructions to confirm the suggested connection method listed below, and check functionality with one solenoid before fully installing the system.

5. Use the large black and grey wire connector (c) to join the one black wire from each solenoid to the common (typically black) wire from the controller. Place the wires to be joined together, with the ends of the insulation even. Twist the connector clockwise onto the wires, pushing firmly until hand tight. Do not over tighten. While tightening, wipe sealant in and around the wires and the opening. Do not reuse connectors.

6. Using one of the four smaller black and white connectors (d), connect the red wire from solenoid valve #1 to one of the remaining controller cable wires (Fig 4). Repeat with the other connectors until all the solenoid wires have been connected. eZyvalve[®]4 solenoid valves are marked 1 to 4 inside the box above the outlets. By checking the wire colour at your irrigation controller, you can ensure that the valve numbering sequence matches that of the controller. (Fig 6 wiring diagram)

(continued overleaf)

eZyvalve[®]4

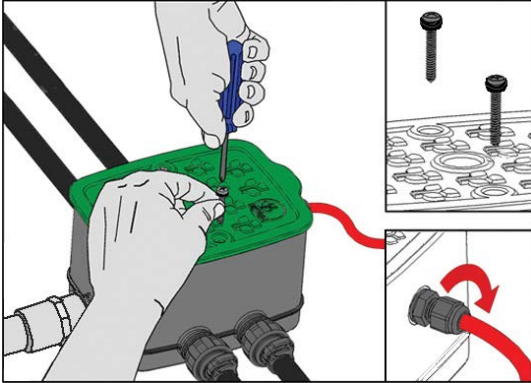

(Fig 5)

7. Pull excess controller cable back through the cable gland to adjust for excess wire in the valve box and lighten the hexagonal sealing nut on the outside of the valve box.

8. Arrange connectors and wires to allow proper closure of the lid. Push the lid (b) in place, making sure the "O" ring seal and inside of the housing are clean to ensure sealing. Install and tighten the lid screws (a), checking that the rubber washers are in place on the screws to maintain a seal. (Fig 5)

Refer to your irrigation controller instructions for further information on connecting your eZyvalve[®]4. Test your installation to ensure that wiring polarity is correct.

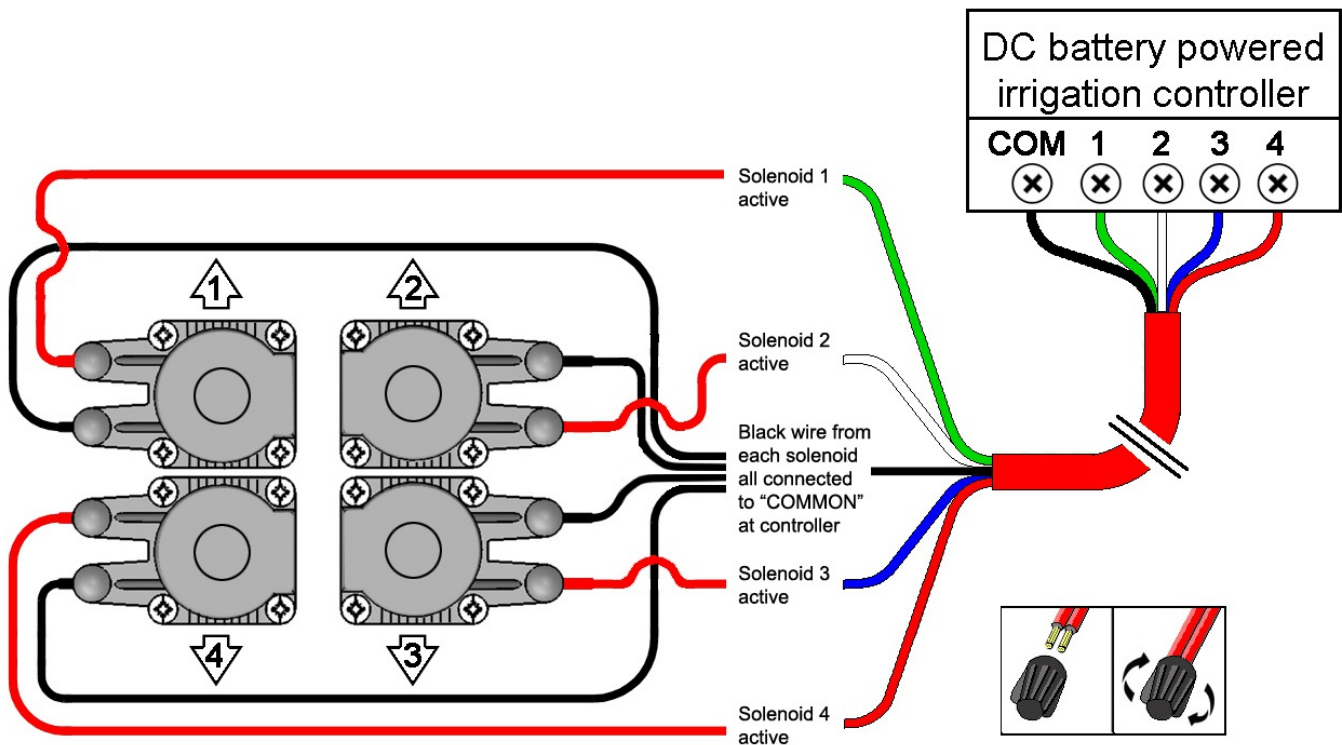

(Fig 6 wiring diagram)